

Sounding system level meter

Sounding-M's

The stable performance at hard conditions ensured.



The SOUNDING M's level meter intergrates reliabl

Sounding M's, the continuous level measurement instrument which integrates all functions corresponding to global standard, supports various applications and performs as the most appropriate level meter guaranteed by MATSUSHIMA.

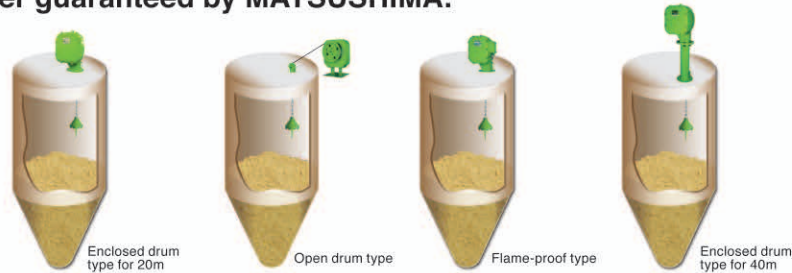

Features

- **The unique control system(Patent No. H5-12648)!**
- **Considerably reduced wiring cost!**
The wiring between Sensor and Controller requires only 4 core cable(CVV-S).
- **Easy maintenance!**
The mechanical and electrical parts are drastically cut from the Sensor to be installed at silo/hopper.
- **Controller equipped with all necessary functions!**
Adjustment is only span setting and can be freely set with Controller!
Only inputting the figures according to the display, that's all. No tiresome adjustment. No need to call specialist/engineer.
The measuring depth is up to 40m as standard and span setting can be freely set.
- **Free to choose Controller from the separated type and the built-in type!**
- **Wire-rope system, superior in durability and easy in replacement work!**
Stable measurement under tough conditions!
The Sensor protection class is IP55 and also wire drum part and electrical part are separated.
The stable measurement is provided under tough conditions.
- **High-temperature, Corrosion-proof, High-pressure types available as option!**
Flame-proof type available as standard lineup!
- **Appropriate application, maintenance and consultation are provided!**
MATSUSHIMA will provide the application, maintenance and consultation suitable for each device based on the long-term supply experiences.

Standard specification

Type	Open drum type	Enclosed drum type	Open drum type	Enclosed drum type
	MDMC-2K	MDMC-2S	MDMC-4K	MDMC-4S
Measuring range	0~20m		0~40m	
Power	AC100V 50/60Hz AC110V 60Hz ±10% (150VA)			
Ambience	temperature : -10~50°C protection structure IP55			
Output Signal	DC4~20mA (DC20~4mA measuring display is possible) isolate output, load resistance 500Ωor less			
Measuring accuracy	1% (Resolution : 0.1%)			
Contact Output	Upper limit, lower limit, and measuring signal: each 1a Alarm(any of CPU fault, thermal trip, weight-buried, wire-broke) : 1a (Normally Close) Contact capacity: AC 250V 2A (DC 60V 1A)			
Measuring Mode	Measuring input contact : manual measurement with One-Shot ON Measuring input contact : auto measurement with Self-Hold ON Interval : Adjustable 1~9999sec *Consider the motor operating rate 40%ED and measuring time.			
Measuring Frequency	Continuous measuring is available			
Rope Speed	12.5 / 14.9m / min			

- [Option] ●Wetted part material:SUS304 ●High temperature type : object temperature 200°C max
 ●Pressure-resistant case : 20kPa max ●Sensing Weight : For powder, fine powder, all sorts of weight
 ●Power : AC200V 50/60Hz ●Built in controller

le technologies and a wide variety of experiences.

Sounding M's (Main body)

Weight Position Scale

Operating Motor

90W, Equipped with B-class insulation brake.

Wire Rope

φ3mm SUS304

Sensing Weight

Open drum type SS400 5kg
Enclosed drum type FC200 4kg
Object gravity more than 0.8g/cm³*1
[Option : SUS304]

*1. Standard Sensing Weight is applicable down to density 0.8g/cm³.
Density below 0.8g/cm³ is also applicable as option.

Measuring Switch

Used under inspection.

Power Switch

Used under inspection.

Lead Outlet

G1/2

Terminal

Connects to controller by 4 core cable.

Casing(aluminum diecast)

Pressure-resistant on wire drum part 5kPa
Option:
Wetted part material SUS304
Pressure-resistance 20kPa

Sounding M's (Controller)

Fail-safe Lamp

This lamp displays the type of alarm.

Upper·lower limit signal Lamp

The lamp is turned on when the upper·lower limit signal is outputted. Hysteresis can be optionally set on upper/lower limit signal.

Output signal Setting Lamp

The lamp is turned on while setting DC4mA or DC20mA level.

50/60Hz Switching Lamp

For switching the power frequency.

Interval Lamp

Adjustable from 1 to 9999 seconds.

Power Lamp

The lamp is turned on when power is entered.

4 figures Digital Indicator

Displays measured value by "cm" or "%".
Displays parameter under setting.

Push-button Switch for Setting

Every parameter of measurement program can be set with three push-button switches.
Set value is memorized even if the power is cut off.

Push-button Switch for Testing

Used for manual measuring.

Push-button Switch for Resetting

Used for recovering fault.

Connection Diagram

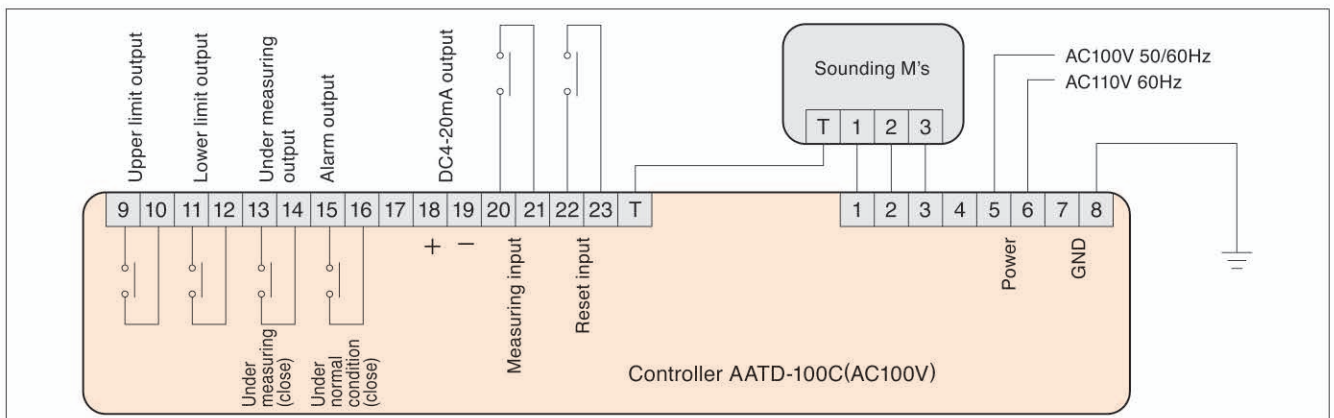

Dimension Diagram in mm

MDMC-2S

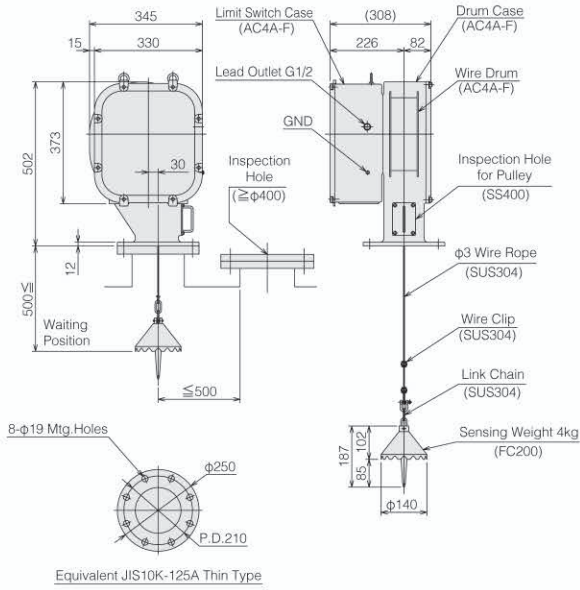

Approx Mass:32kg

MDMC-4S

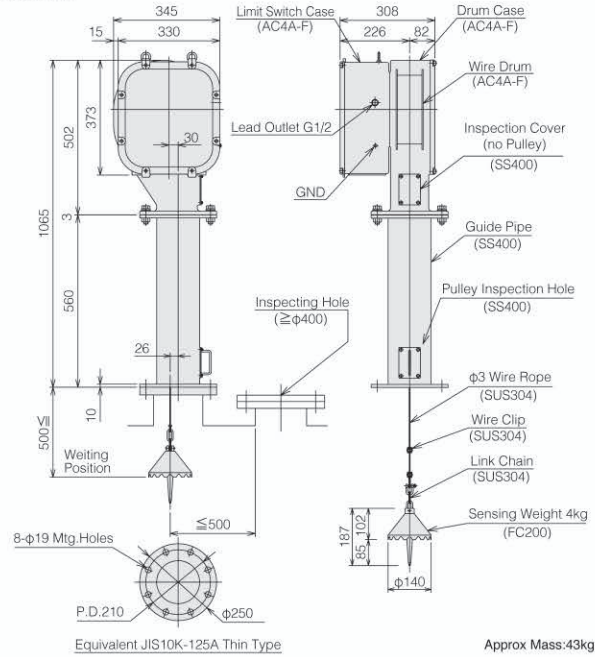

Approx Mass:43kg

MDMC-2K(MDMC-4K)

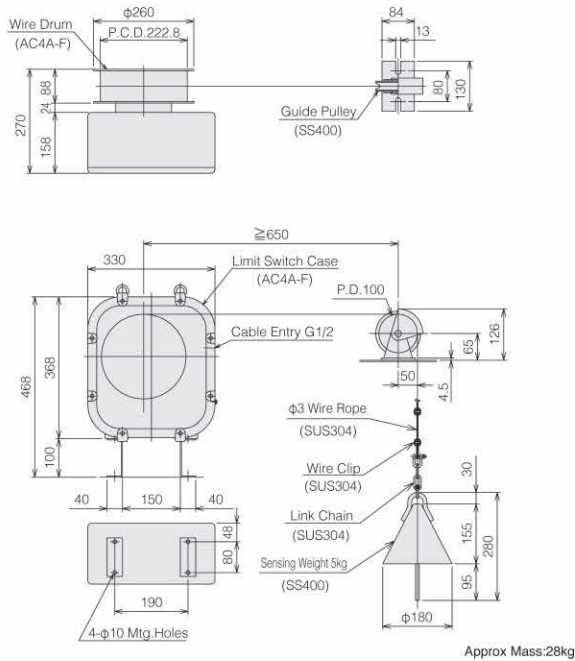

Approx Mass:28kg

AATD-100C
AATD-200C

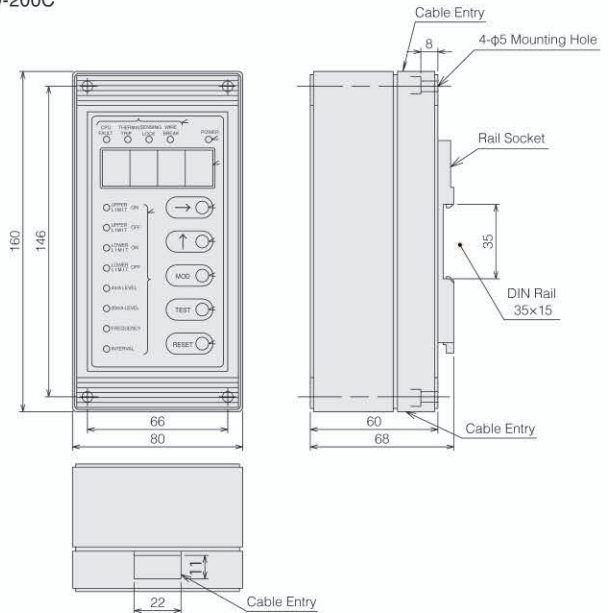

Approx Mass:0.8kg

Specifications are subject to change without notice.
All Rights Reserved Copyrights©2023, Matsushima Measure tech Co., Ltd.



Caution
•Read the instructions to ensure correct and suitable application of products.
•Contact our nearest sales office when using our products for any systems used in situations which may be life threatening.

Distributor



Head office and factory

Matsushima Measure Tech Co., Ltd.

HEAD OFFICE
1-8-18, NORIMATSU-HIGASHI, YAHATANISHI-KU, KITAKYUSHU, 807-0837 JAPAN
Tel: +81-93-691-3731 FAX: +81-93-691-3735
<https://www.matsushima-m-tech.com> E-mail: info@matsushima-m-tech.com

Seoul Branch Office
220, 2F Hyundai Knowledge Industry Center, 70, Dusan-ro, Geumcheon-gu, Seoul, Republic of Korea
Tel: +82-(0)2-852-3731 FAX: +82-(0)2-852-3734

Affiliated company
Shanghai Dahong Matsushima Machinery Co., Ltd.
70 Hengcang Road, Dahong, Malu, Jiading, Shanghai 201818, China
Tel: +86-(0)21-5951-4138 FAX: +86-(0)21-5951-4139