

Thermal Imaging Camera

for 24/7, Day/Night monitoring camera solution

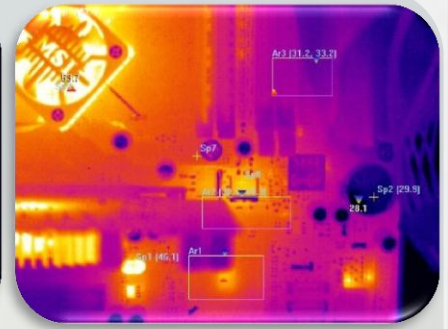
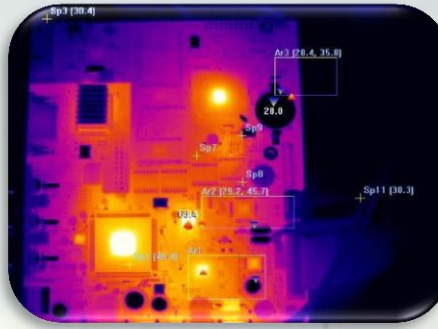

The CX series are extremely affordable thermal imaging cameras. They provide crisp and clear image in total darkness, light fog or smoke.

They can be configured with various lenses for medium-range observation.

You can easily install and integrate CX-series into any existing CCTV or monitoring infrastructure.

The operation is also easy, no operator training is required.



Key Feature

- Output Temp. RAW DATA and analogue image simultaneously!
- Crisp and clear Images
: 384 x 288 pixels, 25um
- Easy to configure and operate
- Easy to install
- Remote camera control via RS-485, Ethernet
- Electronic zoom x2, x4
- Small size and weight

Applications

- Border control
- Commercial Surveillance
- Perimeter security
- Firefighting
- Law enforcement
- Night vision
- Maritime, Airborne
- Research & Development
- Building Diagnostics
- Furnace & Boiler Inspection

Technical Specification

Features	Description / Performance
Detector Type	FPA, Uncooled ASi Microbolometer 384x288 pixels
Image Frequency	50Hz(PAL)/60Hz(NTSC)
Spectral Band	8~14μm
Field of View	CX-320U: 22.6° with 20mm lens CX-350U: 9.1° with 50mm lens CX-375U: 6.1° with 75mm lens CX-3100U: 4.6° with 100mm lens Lenses are interchangeable by factory only
Thermal Sensitivity	<80mk @ f/1, 60Hz, 300K
Accuracy(% of Reading)	±2°C or ±2%
Temperature Range	Normal Range : -20°C~120°C High Range : -20°C~650°C (optional)
Video Output	NTSC / PAL
Operating Voltage	DC 12V
Power Consumption	<6W
Electronic Zoom	2x, 4x
Interfaces	RS485 (PELCO D), Ethernet 10/100 base (Temp. Raw Data)
Image Setting	Automatic Gain Control(AGC), Image Enhancement, NUC(Auto, Manual, Interval), Menu OSD
Operating Temperature	-15°C~50°C
Storage Temperature	-40°C~70°C

Range performance

CX-320U



MAN
█ Detection : 404m
█ Recognition : 96m



OBJECT
█ Detection : 1161m
█ Recognition : 310m

CX-350U



MAN
█ Detection : 1002m
█ Recognition : 239m



OBJECT
█ Detection : 2881m
█ Recognition : 768m

CX-375U



MAN
█ Detection : 1499m
█ Recognition : 357m



OBJECT
█ Detection : 4309m
█ Recognition : 1149m

CX-3100U



MAN
█ Detection : 2409m
█ Recognition : 575m



OBJECT
█ Detection : 6926m
█ Recognition : 1847m

Dimensions

Without Lens (unit : mm)

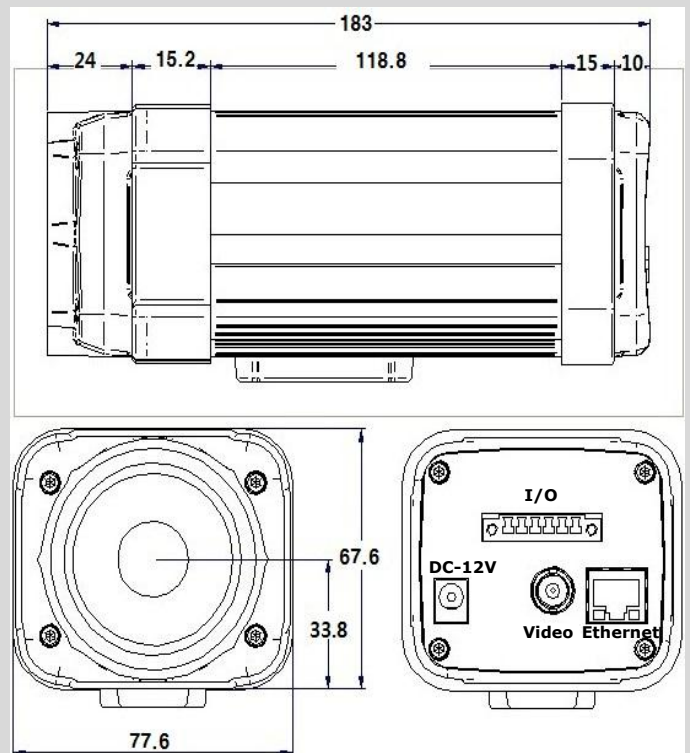

(Weight : 630g)

*Actual range may vary depending on camera set-up, environmental conditions, user experience and type of monitor of display used.