

## SWE-73-S

- ▣ low-cost meter in a small case
- ▣ no analog input
- ▣ RS-485 / Modbus RTU
- ▣ MASTER / SLAVE
- ▣ IR remote controller  
as accessory



The **SWE-73-S** efficiency indicators are low-cost and affordable panel-mounted digital indicators. They are available in three versions: with serial input (-S), current/voltage (-A, description on pages 1.2.1) and temperature (-T, description on page 1.3.1). The 16-bit A/D converters used in them ensure very high stability and measurement precision. Parameters can be programmed freely through an infrared link or through the RS-485 interface, built-in as a standard. Configuration of the device can also be programmed to the customer's order. The RS-485 interface makes it easy to set up measurement networks in production process monitoring systems, and also to use the indicators as smart, programmable, digital converters of input signals for computer systems. An additional advantage of the device is that its dimensions are small and it can be easily mounted.

- all parameters are freely programmable from the PC or remote control (e.g. indication filtering range).

### Typical applications

1. Indication of current values of any parameters,
2. Application wherever there is a need for a quick view of many parameters, i.e. in a synoptic system.

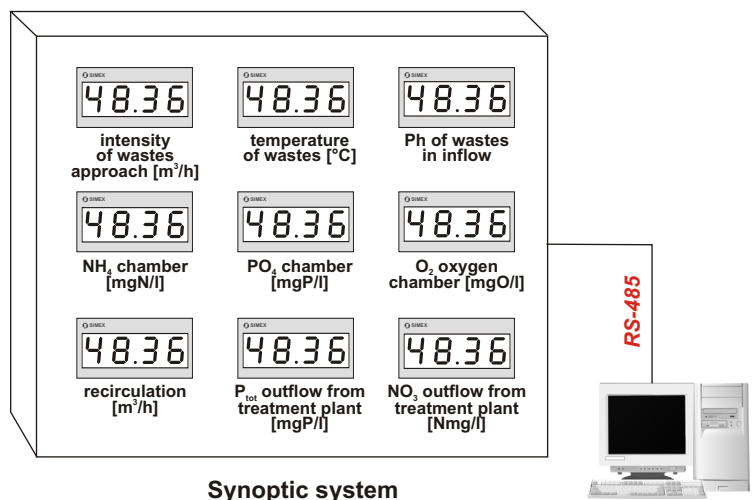

### Exemplary pin assignment

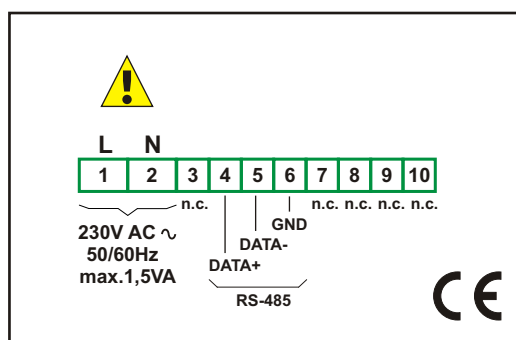

### Ordering

**SWE-73-S-X-XX1**

**options:**

- 00** : no options
- 01** : IP 65
- 08** : operating temp.  
-20°C ÷ +50°C

**power supply:**

- 1** : 24V DC
- 2** : 230V AC
- 8** : 110V AC

### Technical data

**Power supply:** 110V AC ± 10% separated, 230V AC ± 10% separated or 24V DC (10V ÷ 30V DC) not separated  
**Power consumption:** for 110V AC and 230V AC: max. 1,5 VA; for 24V DC: max. 1 W  
**Display:** LED, red, 4 x 13 mm high  
**Displayed values range:** -999 ÷ 9999 + decimal point  
**Communication interface:** RS-485 (Modbus RTU - SLAVE), not galvanically insulated  
**Transmission speed:** adjustable in range from 1200 to 115200 bit/sek.  
**Transmission parameters:** 8N1 and 8N2  
**Operating temperature:** 0°C ÷ +50°C (standard), -20°C ÷ +50°C (option)  
**Storage temperature:** -10°C ÷ +70°C (standard), -20°C ÷ +70°C (with option 08)  
**Protection class:** IP 40 (front side); IP 65 (front side when an optional seal is installed); IP 20 (case and connection clips)  
**Case:** board  
**Case material:** NORYL UL94V-0  
**Case dimensions:** for version 24V DC: 72 x 36 x 77 mm  
for 110V and 230V AC: 72 x 36 x 94 mm  
**Panel cut-out dimensions:** 67 x 32,5 mm  
**Installation depth:** for version 24V DC: min. 78 mm; for 110V and 230V AC: min. 95 mm  
**Board thickness:** max. 5 mm

### Accessories



IR remote controller  
**SIR-15**