

GSM CONTROLLER

Model : GSM8000

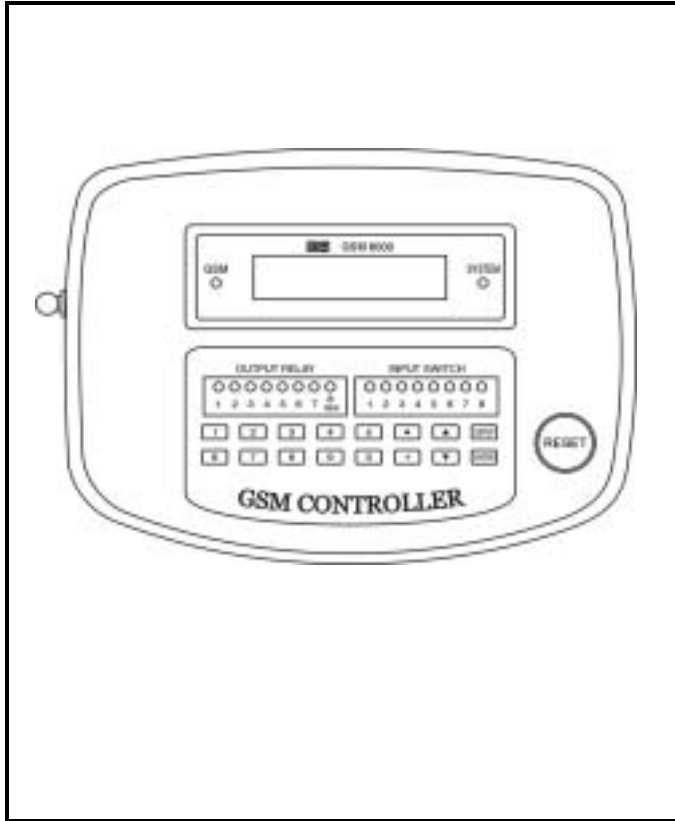

BRAINCHILD ELECTRONIC CO.,LTD.

UMGSM8000A

TABLE OF CONTENTS

1. FEATURES.....	1
2. APPLICATION.....	2
3. SPECIFICATIONS.....	3
4. FRONT PANEL & LAYOUT DESCRIPTION.....	5
5. SIM CARD ACQUISITION and INSTALL.....	8
6. OPERATION PREPARING.....	9
7. FUNCTION SETUP.....	10
7-1 AD (Analog input, 4-20 mA).....	10
7-2 IO (Switch input, Relay output).....	15
7-3 TEL (Telephone).....	17
7-4 RP (Ring period).....	19
7-5 IM (Switch input management).....	20
7-6 SAVE.....	21
8. SMS COMMAND from MOBILE CONFIRM SMS from SYSTEM ERROR SMS COMMAND ALARM SMS from SYSTEM.....	22
9. IMPORTANT OPERATION PROCEDURES and CONSIDERATION.....	31
10. TROUBLE SHOOTING.....	37
11. UNIT LIST of ANALOG INPUT.....	39

1. FEATURES

- * Control/Monitor/Alarm via GSM mobile phone, no distance limitation. User can control/monitor/alarm their device from over the world.
- * 8 channels Analog input (4 -20 mA), can cooperate full line industrial 4-20 mA transmitters.
- * 8 Relay outputs.
- * 8 Switch inputs, normal open, close alarm.
- * 8 Analog inputs : system can preset 4 mA and 20 mA input value according the real measuring value and setting display unit. It can read actual measuring data via the SMS (Short Message) requesting, such as CH1= 28.0 C. CH2=53.7 %RH, CH3=7.01 pH.....CH8= 230.5 ACV.
- * Setting Analog input alarm (High alarm, Low alarm) to enable or disable via SMS.
- * Setting Input switch alarm (close alarm) to enable or disable via SMS.
- * Relay output On/Off setting via SMS.
- * Dot matrix LCD display, show Analog input value, Switch input and Relay output status.
- * All setting value will be saved into EPROM IC, no loss.
- * Mobile telephone can call all channel measuring value, status of Switch input and Relay output at any time.
- * Can default two telephone no., alarm SMS can be send to two users.
- * Build GSM mobile modem (dual band).
- * After the SMS command send by mobile phone, the confirm message will be send back to the mobile, safety and no loss.

2. APPLICATION

- * Industrial remote monitor/controller/alarm system.
- * Industrial security system.
- * Home security system.
- * Building supervision.
- * Industrial systems.
- * Pumping stations.
- * Power station.
- * Agriculture usage.
- * Animal husbandry.
- * Water supply systems.
- * Traffic systems.
- * Railway systems/Vehicles.
- * Energy systems.
- * Water clarification.
- * Heating power plants.

3. SPECIFICATIONS

DISPLAY	Dot-matrix LCD with back light 16 characters x 2 line.	
GSM Modem	900/1800 MHz, dual band.	
Switch inputs	Number	8 inputs
	Reaction time	200 mS, min.
	Status	Default open, Close will alarm
Analog input 4 to 20 mA	Number	8 channels
	Input impedance	125 ohm
	Resolution	12 bits A/D converter
	Setting by front buttons	4 mA. 20 mA setting Unit setting High/Low alarm value setting
Relay outputs	Number	8 relays
	Function	Relay 1 to Relay 7 can control by mobile via SMS Relay 8 is the alarm relay used to connect to field alarm system
	Max load	1 ACA/250 ACV
		1 DCA/24 DCV
Standard	CE conformity	

Operating Temperature	0 to 50 (32 to 122)
Operating Humidity	Less than 80% RH.
Power supply	DC 9V.
Power consumption	Less than 400 mA DC.
Size	193 x 149 x 46 mm. (7.6 x 5.9 x 1.8 inch).
Weight	592 g (1.3 LB).
Accessories includes	Operation manual..... 1 PC AC (100 -240 V)/DC (9V, 1 Amp) power adapter..... 1 PC Antenna..... 1 PC

3. FRONT PANEL & LAYOUT DESCRIPTION

Fig. 1

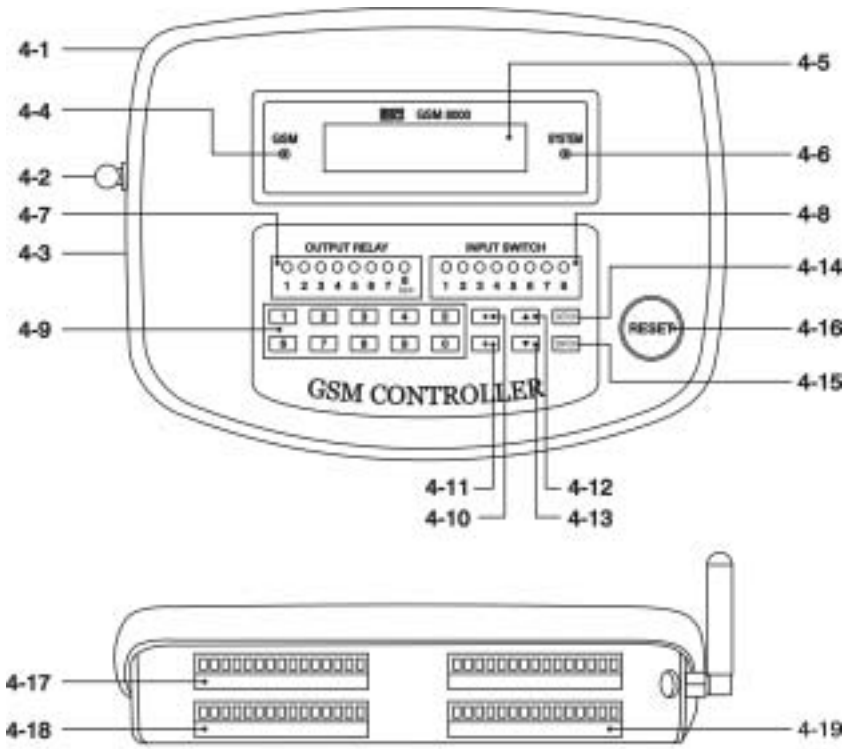

Fig. 2

Fig. 3

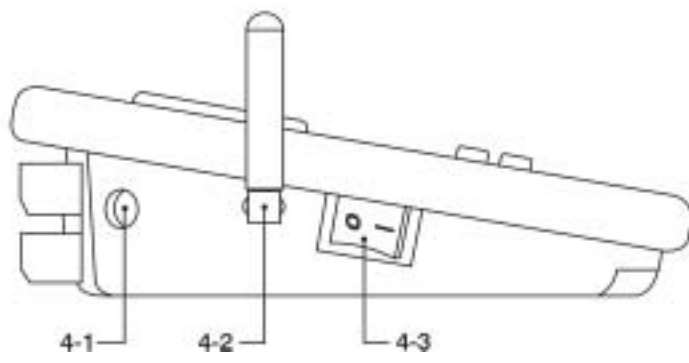
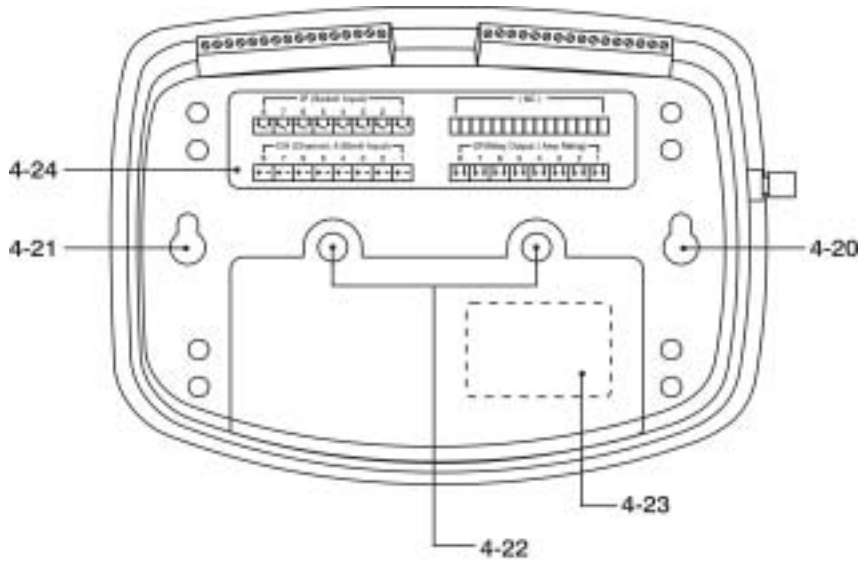

Fig. 4

- 4-1 DC 9V power adapter socket
- 4-2 Antenna and Antenna socket
- 4-3 Power On/Off switch
- 4-4 GSM indicator
- 4-5 LCD display
- 4-6 System indicator
- 4-7 Relay output indicator
- 4-8 Switch input indicator
- 4-9 Numerical buttons
- 4-10 Decimal button
- 4-11 + - button
- 4-12 button
- 4-13 button
- 4-14 SETUP button
- 4-15 ENTER button
- 4-16 RESET button
- 4-17 IP (Switch input) terminals
- 4-18 CH (Analog input, 4-20 mA input) terminals
- 4-19 OP (Relay output) terminals
- 4-20 Fix hole for wall installation
- 4-21 Fix hole for wall installation
- 4-22 Screws for the SIM card cover
- 4-23 SIM card holder
- 4-24 Terminal instruction label

5. SIM CARD ACQUISITION and INSTALL

- 1) Obtain your personal SIM card from the mobile telephone company of your choice.
You will receive a telephone number and a PIN code with your SIM card.
- 2) **Cancel the SIM card's PIN code.**
(No PIN code when use the SIM card)

The procedures to cancel the PIN code, please use your own mobile to proceed as the instruction manual.

Note :

To cancel the PIN code is the necessary procedures, otherwise your GSM system will be not working properly.

- 3) To guarantee flawless operation of your GSM Control System, ensure that adequate signal strength is permanently to and from your mobile telephone network. Check this with your mobile before installation.
- 4) Open the SIM card cover by loosening the " Screws for the SIM card cover " (4-22, Fig. 3). Install the SIM card properly into the " SIM card holder " (4-23, Fig. 3).

6. PREPARING OF OPERATION

- 1) Install the SIM card, refer above chapter 5, page 8.
- 2) Install the antenna to the Antenna socket " (4-2, Fig. 1) properly.
- 3) Connect the plug of the Power Adapter into " DC 9V power adapter socket " (4-1, Fig. 1, Fig. 4)
- 4) Power on the unit by engage the " Power On/Off switch " (4-3, Fig. 1, Fig 4) to the ON position.
- 5) LCD display, System indicator and Output indicator :
 - * The LCD will lit and count down from 90 seconds back to 0 second then present the SETUP SCREEN (refer page 10).
 - * The " Output indicator " (4-7, Fig. 1) will show the default Relay On/Off status, if the Relay On the " Output indicator " will lit.
 - * The " System indicator " (4-6, Fig. 1) will flash (per 1 second On, 1 second Off) if the CPU Circuit working properly.
- 6) GSM indicator (4-4, Fig. 1)
 - a. If the GSM modem is not connecting the mobile network, the " GSM indicator " will flash per 0.6 second On and 0.6 second Off.

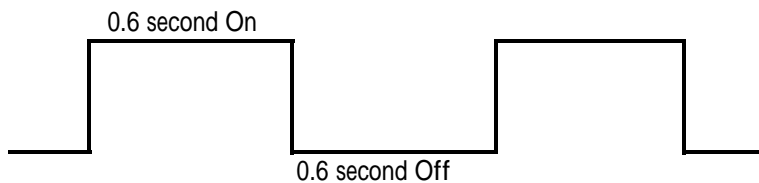

- a. If the GSM modem connect to the mobile network properly, the " GSM indicator " will flash per 0.075 second On and 3 second Off.

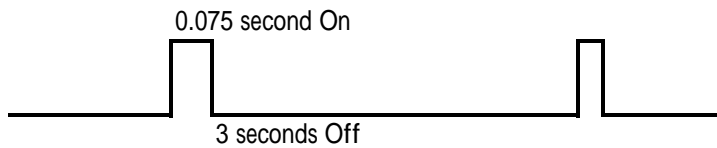

7. FUNCTION SETUP

7-1 AD (4-20 mA Analog input)

- 1) Push the " SETUP Button ", the LCD will show



- * key in " 1 ", LCD will show



- * Use the following buttons

Numerical buttons (4-9, Fig. 1)

Decimal button (4-10, Fig. 1)

+ - button (4-11, Fig. 1)

@ + - button is used to key in " minus " value

to key in the desired channel 1 4 mA value (4 mA = real display value). For example 4 mA = 0

* After finish to key in the desired value, should press the " ENTER " key.

* Press " **CH1 20mA** " button " (4-12, Fig. 1) once, LCD will show

CH1 20mA Value xxxx :	CH1 20 mA setting SCREEN
----------------------------------------	--------------------------

- * Press the buttons (4-9, 4-10 , Fig. 1) to key in the desired channel 1 20 mA value (20 mA = real display value). For example 20 mA = 100.0
- * After finish to key in the desired value, should press the " ENTER " key.

* Press " **CH1 High Limit** " button " once again, LCD will show

CH1 High Limit xxxx :	CH1 High Limit setting SCREEN
----------------------------------------	-------------------------------

- * Use the buttons (4-9, 4-10, Fig. 1) to key in the desired channel 1 High Limit value.
For example High Limit Value = 80.0
- * After finish to key in the desired value, should press the " ENTER " key.

* Press " **CH1 Low Limit** " button " once again, LCD will show

CH1 Low Limit xxxx :	CH1 Low Limit setting SCREEN
---------------------------------------	------------------------------

- * Use the buttons (4-9, 4-10, 4-11, Fig. 1) to key in the desired channel 1 Low Limit value.
For example Low Limit Value = -20.0
- * After finish to key in the desired value, should press the " ENTER " key.

* Press " " button " once again, LCD will show

CH1 Unit : xxxx xx :	CH1 Unit setting SCREEN
---------------------------------------	-------------------------

* Use the buttons (4-9, Fig. 1) to key in the desired no. of display unit. The " DISPLAY UNIT LIST of ANALOG INPUT ", please refer chapter 11, page 39

For example, 01=C, 04=%RH, 17=dB.....

* After finish to key in the desired no., should press the " ENTER " key.

* Press " " button " once again, LCD will show

CHA : xxxxxxxx Enable :	Channel alarm setting SCREEN
------------------------------------------	------------------------------

* Use the buttons (4-9, Fig. 1) to select if the Analog alarm (High limit value alarm, Low Limit value alarm) is enable or disable, x=1 is enable, x=0 is disable.

For example key in " Enable: 11000000 " will set channel 1, channel 2 High/Low alarm is enable, channel 3 to channel 8 High/Low alarm is disable.

* After finish to key in the desired no., should press the " ENTER " key.

* Press " " button " once again, display will return to

CH1 4mA Value xxxx :	CH1 4 mA setting SCREEN
---------------------------------------	-------------------------

* Use " " button " (4-13, Fig. 1) will move the LCD to Channel 2, Channel 3....Channel 8 setting SCREEN
For example :

CH2 4mA Value xxxx :	CH2 4 mA setting SCREEN
---------------------------------------	-------------------------

.....

CHx 4mA Value xxxx :	CHx 4 mA setting SCREEN
---------------------------------------	-------------------------

* In the CHx, press the " " button " to select :

a

CHx 20mA Value xxxx :	CHx 20 mA setting SCREEN
----------------------------------------	--------------------------

b

CHx High Limit xxxx :	CHx High Limit setting SCREEN
----------------------------------------	-------------------------------

c

CHx Low Limit xxxx :	CHx Low Limit setting SCREEN
---------------------------------------	------------------------------

d

CHx Unit : xxxx xx :

 CH1 Unit setting SCREEN

e

CHA : xxxxxxxx Enable :

 Channel alarm setting SCREEN

f

CHx 4mA Value xxxx :

 CHx 4 mA setting SCREEN

* In each channel, the procedures that to key in the desired value are same as above page 10, page 11, page 12.

* After finish all channels (channel 1 to channel 8) setting procedures, it should press " SETUP Button " to return the SETUP screen :

1:AD 2:IO 3: TEL 4:RP 5:IM 6:SAVE

 SETUP SCREEN

Then key in " 6 " (SAVE) LCD will show :

Save OK! SETUP->Exit

* Now the Analog input setting (4mA, 20mA, High limit value, Low Limit value, Unit, Channel alarm enable/disable setting) are finished, all the data will save into the memory circuit permanently. Press the " SETUP Button " will return to the SETUP SCREEN.

7-2 IO (Input, Output)

1) Push the " SETUP Button " once, LCD will show

1:AD 2:IO 3: TEL 4:RP 5:IM 6:SAVE	SETUP SCREEN
--------------------------------------	--------------

* key in " 2 ", LCD will show

OP :xxxxxxx Output :	RELAY ON/OFF SETTING SCREEN
-------------------------	-----------------------------

* Use the " button " to select the setting following
a, b setting SCREEN .

a

OP :xxxxxxx Output :	RELAY ON/OFF SETTING SCREEN
-------------------------	-----------------------------

@ It is to set the Relay On or Off (Relay 1 to Relay 8).

@ **The Relay 8 is the alarm relay, Relay 8 will be On when alarm (Analog High alarm, Analog Low alarm, Switch input alarm) happened. If the alarm message stop, the Relay 8 will Off. Relay 8 can not be controlled by key buttons or mobile SMS command no matter Key in the relay 8 status to " 1 " or " 0 ".**

@ For example : Setting " Output : 11000000 (or 11000001) " will engage the Relay 1 & Relay 2 to be On, Relay 3 to Relay 7 to be Off.
Relay 8 On/Off is determined by the alarm status only.

b.

IPA :xxxxxxx Enable :

 IP ALARM enable/disble SETTING SCREEN

@ It is to set if the input switch alarm enable/disable.

1= alarm enable

0= alarm disable

@ For example, setting " Enable : 11100000 " will engage the Switch 1 to Switch 3 to alarm enable, Switch 4 to Switch 8 is alarm disable.

* Under the above a, b. setting function, use the buttons 4-9, Fig. 1) to select the desired value (0 or 1).

* After finish to key in the desired no., should key in the " ENTER " key.

* Before finish the e" IO " setting, it should press " SETUP Button " to return SETUP SCREEN :

1:AD 2:IO 3: TEL 4:RP 5:IM 6:SAVE

 SETUP SCREEN

Then key in " 6 " (SAVE), LCD will show :

Save OK! SETUP->Exit

7-3 TEL (Telephone)

Press the " SETUP Button " once, LCD will return to
SETUP SCREEN

1:AD 2:IO 3: TEL 4:RP 5:IM 6:SAVE	SETUP SCREEN
----------------------------------------------------	--------------

* key in " 3 ", LCD will show

Telephone Num 1 +	TEL 1 SETTING SCREEN
------------------------------------	----------------------

* Use the " button " to select the " TEL " setting
screen (a. b. c. d.) as :

a

Telephone Num 1 +	TEL 1 SETTING SCREEN
------------------------------------	----------------------

- @ Enter the first mobile telephone no.
- @ Telephone no. starting with + country code (For example, Germany is +49, Taiwan is +886, Hongkong is +852...)
- @ For example key in +886919562822

b

Telephone Num 2 +	TEL 2 SETTING SCREEN
------------------------------------	----------------------

- @ Enter the second mobile telephone no.
- @ The procedures are same as the above TEL 1.

c **Num1: Supervisor**
(0):M , (1):S TEL 1 M/S SETTING SCREEN

- @ Define the first mobile is the Supervisor or Monitor.
- @ 1 = Supervisor, 0 = Monitor
- @ Supervisor mobile can control & monitor the system.
- @ Monitor mobile only can monitor listen the alarm SMS message from the system only.

d **Num2: Supervisor**
(0):M , (1):S TEL 2 M/S SETTING SCREEN

- @ Define the second mobile is the Supervisor or Monitor.

* If only need one mobile telephone to control (monitor),
it just key in one telephone no (Telephone Num 1).

* Under the above a, b. c d screen, use the buttons
4-9, 4-11, Fig. 1) to key in.

* After finish to key in the desired no. or function,
should key in the " ENTER " button.

* Before finish the e" TEL " setting, it should key in
" SETUP Button " to return the SETUP SCREEN.

1:AD 2:IO 3: TEL
4:RP 5:IM 6:SAVE SETUP SCREEN

Then key in " 6 " (SAVE), LCD will show :

Save OK!
SETUP->Exit

7-4 RP (Ring period)

Press the " SETUP Button " once, LCD will show :

1:AD 2:IO 3: TEL 4:RP 5:IM 6:SAVE	SETUP SCREEN
----------------------------------------------------	--------------

* key in " 4 ", the screen will show

RP old value : xx RP new value :	RP SETTING SCREEN
---------------------------------------------------	-------------------

- @ RP function is to set the duration period of alarm SMS, the setting unit is minute.
- @ When happen alarm, the system will send alarm SMS per xx minutes, typical set 03 (3 minutes).
- @ For example, if key in " RP new value = 03 ", the alarm SMS message will send per 3 minutes continuously. The alarm SMS message will stop when alarm is off or disable.

* After finish to key in the desired value., should press the " ENTER " button.

* Before finish the " RP " setting, it should press " SETUP Button " once to return the SETUP SCREEN :

1:AD 2:IO 3: TEL 4:RP 5:IM 6:SAVE	SETUP SCREEN
----------------------------------------------------	--------------

Then key in " 6 " (SAVE), LCD will show :

Save OK! SETUP->Exit

7-5 IM (Switch input management)

Press the " SETUP Button " once, LCD will show :

1:AD 2:IO 3: TEL 4:RP 5:IM 6:SAVE	SETUP SCREEN
----------------------------------------------	--------------

* key in " 5 ", LCD will show

Alarm : Close (Pulse) (0): P , (1): C	IM SETTING SCREEN
-----------------------------------------------------	-------------------

@ IM function is to set the two kind switch alarm
type : Close alarm or Pulse alarm

@ 0 = Pulse alarm, 1 = Close alarm

@ Close alarm type : Input switch is normal open,
if the switch is closed, send the SMS alarm
message out. if the switch is opened again, the
alarm SMS message will stop.

@ Pulse alarm type : Input switch is normal open, if
the switch is closed, send the SMS alarm message
out. if the switch is opened again, the alarm SMS
message will still send continuously no matter the
switch open again.

Under the " Pulse alarm " type, if intend to stop
the alarm SMS, it should do as :

1. From the system " IO " setting function to let
the switch input alarm disable.
2. From mobile to send the SMS command :
(SET-DIP-ALARM 00000000) , refer Chapter 8
page 24.

* Press the " Button " will show " Relay8 action " screen as :

Relay8:Action
(0):N , (1):Y

@ It is to select if the Relay 8 will do action or no.
@ Typically always select to 1 (Yes).

* After finish to set the desired IM function., should press the " ENTER " button.
* Before finish the " IM " setting, it should press " SETUP Button " to return SETUP SCREEN.

1:AD 2:IO 3: TEL SETUP SCREEN
4:RP 5:IM 6:SAVE

Then key in " 6 " (SAVE), LCD will show :

Save OK!
SETUP->Exit

7-6 SAVE

* After the system are already change the data, value, function..., it should press " SETUP Button " to return SETUP SCREEN.

1:AD 2:IO 3: TEL SETUP SCREEN
4:RP 5:IM 6:SAVE

Then key in " 6 " (SAVE), LCD will show :

Save OK!
SETUP->Exit

@ The setting procedures are finished completely, the change data, value and the function will be saved 'into the memory circuit.

**8. SMS COMMAND from MOBILE
SMS CONFIRMATION from SYSTEM
ERROR SMS COMMAND
ALARM SMS from SYSTEM**

***8-1 SMS COMMAND from MOBILE
SMS CONFIRMATION from SYSTEM***

*There are 6 types of SMS would be send from the
mobile are :*

**SET-DOP xxxxxxxx
SET-DIP-ALARM xxxxxxxx
SET-CH-ALARM xxxxxxxx
GET-CH
GET-STATE
RESET**

SET-DOP xxxxxxxx

@ x= 1 or 0, 1 = Relay On, 0 = Relay Off
 @ SMS command from mobile to set the Relays' out to be On or Off

@ The relay 8 is the alarm relay. Relay 8 will be On when alarm (High value alarm. Low value alarm, Input switch alarm) happened. If the alarm message stop, the relay 8 will Off. Relay 8 can not be controlled by key buttons or mobile SMS no matter set the relay 8 status to " 1 " or " 0 ".

@ For example, SET-DOP 11000000 (or 11000001)
 The Relay 1, Relay 2 will be On, Relay 3 to Relay 7 will be Off. On/Off of RELAY 8 is depend on the alarm status.

@ For example, After mobile send the SMS (SET-DOP 11111111x) to the system, the mobile will get the SMS confirmation from the system back as :

OP(1-8)= HHHHHHHL	→	Relay 1-8 On or Off H=Relay ON, L=Relay Off
IP(1-8)= OOOOOOOO	→	Input Switch Close or Open O=Open, C=Close
CHAM(1-8)= 00000000	→	Analog alarm enable/disable 0=disable, 1=enable
IPAM(1-8)= 00000000	→	Input switch alarm enable/disable 0=disable, 1=enable

SET-DIP-ALARM xxxxxxxx

@ SMS command from mobile to set alarm status is enable or disable of the the IP (Switch input).

@ x = 1, Input switch alarm enable
 x = 0, Input switch alarm disable

@ For example, SET-DIP-ALARM 11000000
 The IP1, IP2 will be alarm enable, IP3 to IP8 will be alarm disable

After mobile send the SMS (SET-DIP-alarm xxxxxxxx) to the system. The mobile will get the confirmation SMS from the system back as :

For example :

If mobile send the SMS (SET-DIP-ALARM 11000000) The mobile will get the SMS confirmation from the system back similar as

OP(1-8)= HHHHHHHL	→	Relay 1-8 On or Off H=Relay ON, L=Relay Off
IP(1-8)= OOOOOOOO	→	Input Switch Close or Open O=Open, C=Close
CHAM(1-8)= 00000000	→	Analog alarm enable/disable 0=disable, 1=enable
IPAM(1-8)= 11000000	→	Input switch alarm enable/disable 0=disable, 1=enable

SET-CH-ALARM xxxxxxxx

@ SMS command from mobile to set Analog
(4-20 mA Analog input) alarm status is enable
or disable.

@ x = 1 Analog alarm enable, x = 0 Analog alarm disable

@ For example, SET-CH-ALARM 11000000

The CH1, CH2 will be alarm enable, CH3 to CH8 will
be alarm disable

After mobile send the SMS (SET-CH-alarm xxxxxxxx)
to the system. The mobile will get the confirmation
SMS from the system back as :

For example :

If mobile send the SMS (SET-CH-ALARM 11000000)

The mobile will get the SMS confirmation from the
system back similar as :

OP(1-8)= HHHHHHL	→	Relay 1-8 On or Off H=Relay ON, L=Relay Off
IP(1-8)= OOOOOOOO	→	Input Switch Close or Open O=Open, C=Close
CHAM(1-8)= 11000000	→	Analog alarm enable/disable 0=disable, 1=enable
IPAM(1-8)= 00000000	→	Input switch alarm enable/disable 0=disable, 1=enable

GET-CH

@ SMS command from mobile to get CH (Channel, 4-20 mA Analog input) information.

After mobile send the SMS (GET-CH) to the system, The mobile will get the confirmation SMS from the system back as :

For example :

CHS=HHLLLLL	→	Channel H/L/N status
C1=980.5 m/s	→	H=Reading on High value
C2=245.2 ACV	→	L=Reading on Low value
C3=980.5 WATT	→	N=Reading on Normal value
C4=8.634 pH	→	CH1 reading value with unit
C5=200.5 uS	→	CH2 reading value with unit
C6=99.52 ACA	→	CH3 reading value with unit
C7=502.4 Lux	→	CH4 reading value with unit
C8=75.91 dB	→	CH5 reading value with unit
		CH6 reading value with unit
		CH7 reading value with unit
		CH8 reading value with unit

GET-STATE

@ SMS command from mobile to get the following information :

OP :

Relay On/Off

IP :

Switch input Close/Open

CHAM :

Channel alarm (4-20 mA input alarm) enable/disable

IPAM :

Input switch alarm enable/disable

After mobile send the SMS (GET-STATE) to the system, the mobile will get the SMS confirmation from the system back as :

For example :

OP(1-8)= HHHHHHHL	→	Relay 1-8 On or Off H=Relay ON, L=Relay Off
IP(1-8)= OOOOOOOO	→	Input Switch Close or Open O=Open, C=Close
CHAM(1-8)= 00000000	→	Analog alarm enable/disable 0=disable, 1=enable
IPAM(1-8)= 11000000	→	Input switch alarm enable/disable 0=disable, 1=enable

RESET

- @ SMS command from mobile to reset the system.
- @ After mobile send the " RESET " SMS command to the system, the system will not send any SMS confirmation to the mobile, it just to execute the reset function to the system only.

8-2 ERROR SMS COMMAND

If the mobile send the wrong or illegal SMS command to the system, the system will send the following SMS back to mobile to hint operator that the SMS command is wrong :

WRONG INSTRUCTIONS !

8-3 ALARM SMS from SYSTEM

There are two kinds of alarm (Analog High/Low alarm, Input switch alarm) SMS will send out from the system to the mobile if the alarm happened.

a. Analog High/Low alarm (CH ALARM)

The mobile will get the following alarm SMS from the system as example :

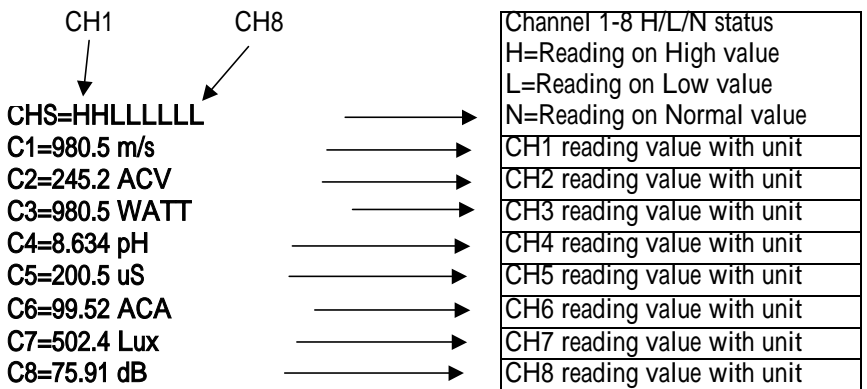

b. Input switch alarm (IP ALARM)

The mobile will get the following alarm SMS from the system as example :

Switch input 1-8

(1:Close)
2:Open
3:Open
4:Open
5:Open
(6:Close)
7:Open
8:Open

Switch 1 and Switch 6
are Closed

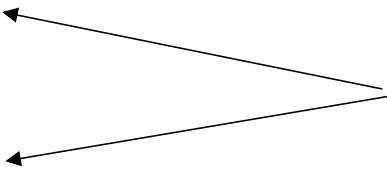

@ If the switch has been bracketed, it indicate that this switch alarm send already.

@ The content text (Close or Open) shows the existing switch status.

For example :

(6:Close), it indicates that the Switch 6 has been changed , alarm SMS send and the existing Switch status is " Close " when the time that system send alarm SMS out..

9. IMPORTANT OPERATION PROCEDURES & CONSIDERATION

- 1) If system under normal operation, the LCD display should select to the Regular SCREEN, otherwise the system can not accept SMS in or send the SMS out.

Push the " SETUP Button " once again, the LCD will change to SETUP SCREEN to Regular SCREEN alternatively. For example :

a. SETUP SCREEN

1:AD 2:IO 3: TEL 4:RP 5:IM 6:SAVE	SETUP SCREEN
--------------------------------------	--------------

a. Regular SCREEN

If the LCD already present any Regular SCREEN, it can use the " Button " or " Button " to select the following different kind Regular SCREEN

a

CH1=>xxxxxx xxx LO:xxxx H:xxxx	Regular SCREEN (CH1)
-----------------------------------	------------------------

CH1 Analog input, High/Low/Normal value

.....

x

CHx=>xxxxxx xxx LO:xxxx H:xxxx	Regular SCREEN (CHx)
-----------------------------------	------------------------

CHx Analog input, High/Low/Normal value

.....

- h

CH8=>xxxxxx xxx LO:xxxx H:xxxx

 Regular SCREEN (CH8)

CH8 Analog input, High/Low/Normal value
@ If the CHx => flashed, it indicate that the channel x already send the " Analog alarm " SMS out.
- i

CH=>12345678 OP=>HHHHHHHL

 Regular SCREEN (Relay On/Off)

H=Relay On, L=Relay Off
- j

CH=>12345678 IP=>OOOOC

 Regular SCREEN
(Input switch, Open/Close)

O=Open, C=Close
@ If the " C " or " O " flashed, it indicate that the channel x already send the " Switch input alarm " SMS out.
- k

CH=>12345678 CHA=>00000000

 Regular SCREEN
(Analog alarm, enable/disable)

0= Analog alarm disable
1= Analog alarm enable
- l

CH=>12345678 IPA=>00000000

 Regular SCREEN
(Input switch alarm, enable/disable)

0= Analog alarm disable
1= Analog alarm enable
- m

CH=>12345678 CHS=>HHLLLLNN

 Regular SCREEN
(Analog High/Low/Normal value Status)

H=High value, L=Low value, N=Normal value

2) RESET Button

If push the " RESET button " (4-16, Fig. 1), the LCD will lit and going on to count down from 90 seconds back to 0 second, then present the SETUP SCREEN. The " Output indicator " (4-7, Fig. 1) will show the default Relay On/Off status if Relay On the indicator will lit. The " Input indicator " (4-8, Fig. 1) will show the Input switch status. If the Input switch is closed the indicator will lit.

The " System indicator " (4-6, Fig. 1) will flash (per 1 second On, 1 second Off) if the CPU Circuit working properly.

At the beginning, the GSM modem is not connecting the mobile network, the " GSM indicator " (4-4, Fig. 1) will flash per 0.6 second On and 0.6 second Off. After the GSM modem already connect to the mobile network properly, the " GSM indicator " will flash per 0.075 second On and 3 second Off.

3) Switch input terminals

Warning !

The " Switch input terminals " (4-17, Fig. 1). are intend to connect the switch input only, do not input any voltage signal to the " Switch input terminals " .

4) Analog Channel, 4-20 mA input terminals

Warning !

The max. input current for the " Analog Channel, 4-20 mA terminals " (4-18, Fig. 1). is DC 20 mA, do not input the current over the full range.

5) Relay Output terminals

Warning !

For the long term operation, for each " Relay Output Terminal " (4-19, Fig. 1), please do not connect the max. load over 1 ACA (250 ACV).

**6) LCD Information between GSM modem
and the CPU circuit**

LCD display

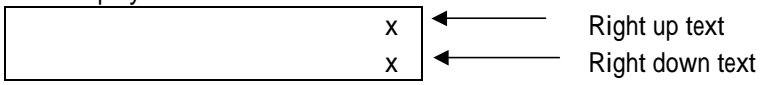

7) Alarm delay time

- a. For Analog alarm, after measuring value over (under) High limit value (Low limit value) 15 seconds continuously, system will send alarm SMS out if alarm function is enable
- b. For Switch input alarm (close alarm type), after switch is closed 3 seconds continuously, system will send alarm SMS out if alarm function is enable

10. TROUBLE SHOOTING

- 1) When the mobile send the SMS command to system, mobile get the following SMS conformation :

WRONG INSTRUCTION !

Corrective action :

SMS command entry error (typing error) ?

Repeat the command exactly as the specification.

- 2) When the mobile send the SMS command to system, the right up (down) text of LCD show some text (refer page 35) but the system do not execute the action as the desired function.

Corrective action :

The system may possibly not key in the right mobile telephone number?

Please check and key in telephone no. again.

- 3) Power on the system, but the " GSM indicator " is not finished.

Corrective action :

May be the GSM modem is not triggered.

Power off, wait at least 10 seconds, then power on.

The duration between power Off and power On, should wait at least 10 seconds.

- 4) The system do not send the alarm SMS out as the desired.

Corrective action :

Check if the system set the alarm function to disable ?
Setting the enable alarm function again.

- 5) After power On the system, the GSM modem do not connect to the mobile network (GSM indicator just flash per 0.6 second On and 0.6 second Off).

Corrective action :

Check if you already cancel the PIN code of SIM card ?
Use your mobile to check the SIM card.

**If the network signal strength is too weak,
please use the optional separate antenna to
instead the original antenna (included).**

- 6) When the mobile send the SMS command to the system, the mobile does not get any SMS confirmation as desired.

Corrective action :

May be the LCD SCREEN select to SETTING SCREEN.
Under normal operation, the LCD display should select to the Regular SCREEN, other wise the system can not accept SMS in or send the SMS out.
Refer Chapter 9, Page 31, Page 32.

11. Display Unit of Analog input

00 = NO UNIT	26 = ATM
01 = C	27 = RPM
02 = F	28 = in/m
03 = %	29 = cm/m
04 = %RH	30 = COUT
05 = pH	31 = Hz
06 = %O2	32 = DEG
07 = mg/L	33 = KHz
08 = m/s	34 = metr
09 = knot	35 = uA
10 = km/h	36 = inS2
11 = ft/m	37= mA
12 = ml/h	38 = ohm
13 = uS	39 = Kohm
14 = mS	40 = Mohm
15 = Lux	41= mH
16 = Ftcd	42 = in/s
17= dB	43 = nF
18= uWcm	44 = uF
19 = PPM	45= DCuA
20 = mg	46 = cm
21 = Tesl	47= WATT
22 = bar	48 = KWAT
23 = PSI	49 = ACmV
24 = cmHg	50 = ACV
25 = iH20	

51 = ACuA	76 = SEC
52 = ACA	77 = Kgcm
53 = ACmA	78 = mmHg
54 = PF	79 = mH2O
55 = Kg	80 = inHg
56 = Lb	81 = VAR
57= gram	82 = Lbin
58 = oz	83 = N-cm
59 = NewT	84 = CMM
60 = m/m	85 = CFM
61= Hour	86 = mbar
62= Min	87 = Pa
63 = VA	88 = kPa
64 = KVA	89 = uHg
65 = KWHR	90 = Torr
66 = mF	91 = hPa
67 = MHz	92 = m/s2
68 = uH	93 = mm/s
69 = mGAU	94 = mm
70 = DCV	95 = mWcm
71 = DCA	96 = inch
72 = DCmA	97 = FtS2
73 = DCmV	98 = inS2
74 = mSEC	99 = GAUS
75 = cm/s	