



熱電偶 Thermocouple

電阻式測溫體 Resistance Temperature Detector

熱電偶 T/C：把兩種不同材質之金屬，以電氣焊接，使其產生密閉迴路，在焊接端加熱，產生溫差，即是熱電偶的生成。

電阻式測溫體 RTD：一般金屬導體，其電阻均隨溫度之變化而改變，運用此溫度係數之特性，可由電阻之變化，而求得溫度，藉此原理來測量溫度之計測器，稱之電阻式測溫體。



可彎曲熱電偶 Sheathed Thermocouple

可彎曲熱電偶 Sheath T/C：極細金屬管(Sheath)與熱電偶素線間以高純度氧化鎂粉末慎密堅實充填，使其成爲氣密狀態，並具有超絕緣性與耐高壓性之熱電偶。



保護管 Thermo-Well

保護管 Thermo-Well：採用實心圓棒或六角實心棒，以特別機械設備，依指定規格、條件，挖鑿開孔，以保護並裝置，容納熱電偶素線、細素熱電偶，或電阻式測溫體之金屬保護管。

上述各項商品，歡迎依其所需條件訂製。

產品大類介紹



※各類型熱電偶及測電阻體可依使用環境提供不同材質及型式及 THERMOWELL。
※包括 FLANGED TYPE、DRILLED TYPE 及 TEFLON TYPE。



※針對特殊環境提供(可彎曲熱電偶)(防爆型熱電偶)及稀有金屬保護管，包括 HASTELLOY C、SIC、鉬、鉭、鋳、石墨 . . . 等。





※針對各種治具使用之表面溫度計，搭配溫度顯示器可現場讀取。



※各類補償導線，披覆材質：PVC、玻璃纖維、TEFLON，金屬網線 . . . 等。

熱電偶訂購規格表—I

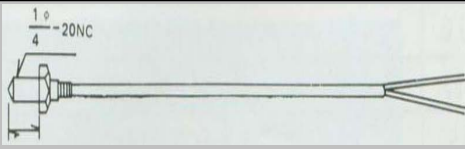
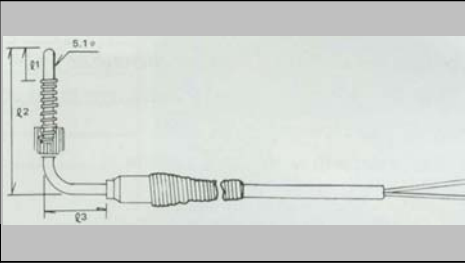
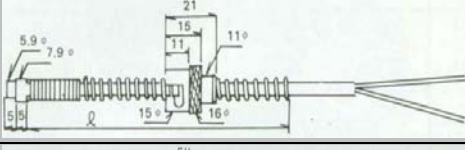
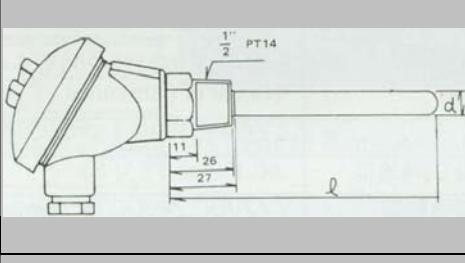
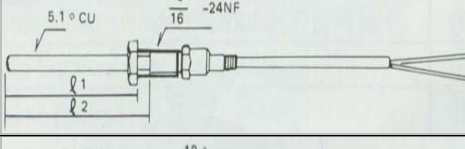
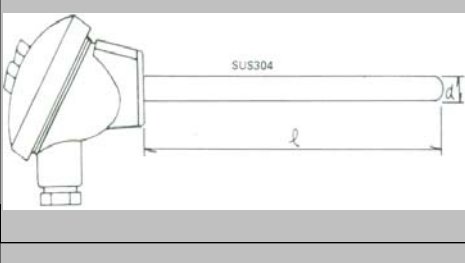
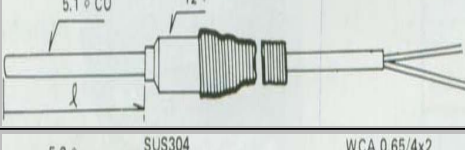
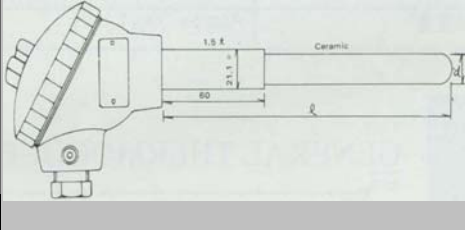
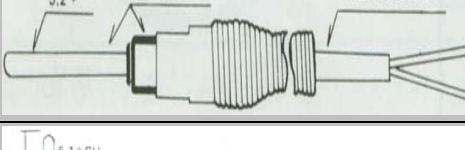
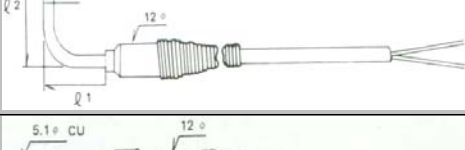
※以下為常用型熱電偶，如有特殊規格歡迎另外訂購。

THERMOCOUPLE			
	MT-101 K & J Type Under 350°C 以下		MT-105-2 K & J Type Under 600°C 以下
	MT-101-8 K & J Type Under 350°C 以下		MT-106 K & J Type 9.5 φ Under 600°C 以下 12.7 φ Under 700°C 以下 15.9 φ Under 800°C 以下 17.3 φ Under 900°C 以下 21.7 φ Under 1000°C 以下
	MT-102 K & J Type Under 600°C 以下		MT-107 K & J Type 9.5 φ Under 600°C 以下 12.7 φ Under 700°C 以下 15.9 φ Under 800°C 以下 17.3 φ Under 900°C 以下 21.7 φ Under 1000°C 以下
	MT-103-1 K & J Type Under 600°C 以下		MT-109 K & J Type Under 600°C 以下
	MT-103-9 K & J Type Under 600°C 以下		
	MT-104 K & J Type Under 600°C 以下		
	MT-105-1 K & J Type Under 600°C 以下		

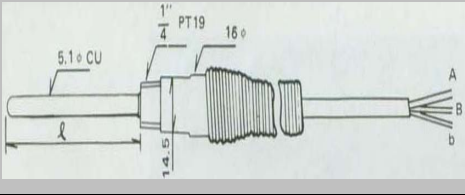
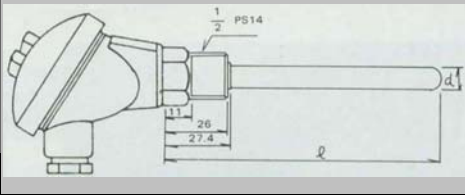
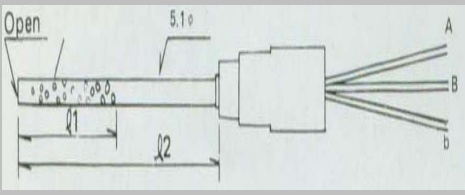
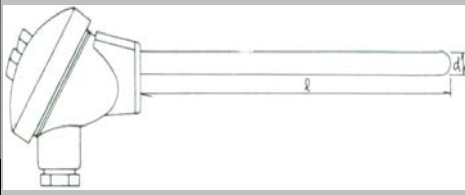
RTD			
	MT-201 PT 100 Ω RTD(3WireSystem) Under 300°C 以下		MT-206 PT 100 Ω RTD(3WireSystem) Under 300°C 以下
	MT-201-6 PT 100 Ω RTD(3WireSystem) Under 300°C 以下		MT-207 PT 100 Ω RTD(3WireSystem) Under 300°C 以下

熱電偶訂購規格表—II

※以下為常用型熱電偶，如有特殊規格歡迎另外訂購。

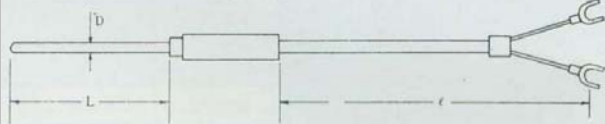
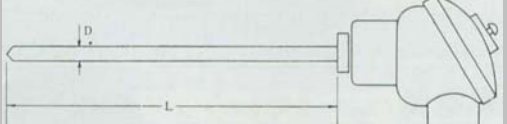
極速熱電偶 (直徑小且可彎曲)	
ST-30	ST-60 With Thread Connection ST-70 Without Thread Connection
	











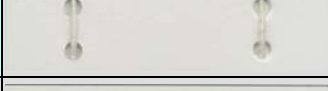

THERMOCOUPLE WIRE 熱電偶材質	SHEATH MATERIAL 保護管材質	SHEATH OUTER DIA. 外徑	1.0 φ	1.6 φ	3.2 φ	4.8 φ	6.4 φ	8.0 φ
			K-TYPE	INCONEL600	500°C	700°C	900°C	1000°C
K-TYPE	SUS316	450	600	700	800	850	900	
J-TYPE	SUS316	250	350	450	500	MAX. WORKING TEMP.		

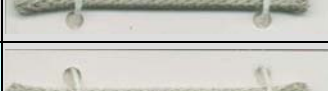
※以下為各式熱電偶頭及磁座訂購規格

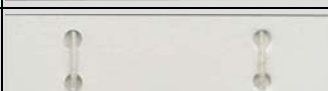



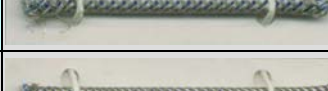
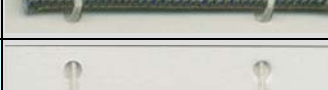







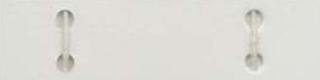

各式熱電偶線訂購規格表—I

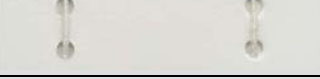
※以下為常用型，如有特殊規格歡迎另外訂購。

代號 WIRE CODE	規格 SPECIFICATION	說明 DESCRIPTION	環境溫度範圍 TEMP. RANGE	樣品 SAMPLE
TC-CA-H	0.32*2	玻璃纖維 CLASS FIBER 素線級 T/C GRADE	0 ~ 200°C	
TC-CA-H	0.65*2	玻璃纖維 CLASS FIBER 素線級 T/C GRADE	0 ~ 200°C	
				
TC-CA-H(OS)	0.65*2	玻璃纖維 CLASS FIBER 銅網外隔離 OVER TINNED COPPER BRAIDED	0 ~ 200°C	
TC-CA-H(SOS)	0.65*2	玻璃纖維 CLASS FIBER 不鏽鋼外隔離 OVER SUS304 STAINLESS BRAIDED	0 ~ 200°C	
TC-CA-H(SOS)	4/0.32*2	玻璃纖維 CLASS FIBER 不鏽鋼外隔離 OVER SUS304 STAINLESS BRAIDED	0 ~ 200°C	
TC-IC-H(OS)	0.65*2	玻璃纖維 CLASS FIBER 不鏽鋼外隔離 OVER SUS304 STAINLESS BRAIDED	0 ~ 200°C	
TC-CC-H(OS)	0.65*2	玻璃纖維 CLASS FIBER 不鏽鋼外隔離 OVER SUS304 STAINLESS BRAIDED	0 ~ 200°C	
TC-PT-H(OS)	0.65*3	玻璃纖維 CLASS FIBER 不鏽鋼外隔離 OVER SUS304 STAINLESS BRAIDED	0 ~ 200°C	
				
WCA-H	4/0.32*2	玻璃纖維 CLASS FIBER	0 ~ 200°C	
WCA-H	7/0.32*2	玻璃纖維 CLASS FIBER	0 ~ 200°C	
WCA-H	4/0.65*2	玻璃纖維 CLASS FIBER	0 ~ 200°C	
WCA-H	7/0.65*2	玻璃纖維 CLASS FIBER	0 ~ 200°C	
WCA-H(SOS)	4/0.65*2	玻璃纖維 CLASS FIBER 不鏽鋼外隔離 OVER SUS304 STAINLESS BRAIDED	0 ~ 200°C	
WCA-H(SOS)	7/0.65*2	玻璃纖維 CLASS FIBER 不鏽鋼外隔離 OVER SUS304 STAINLESS BRAIDED	0 ~ 200°C	
				

各式熱電偶線訂購規格表—II

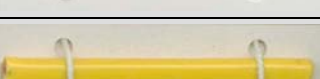
※以下為常用型，如有特殊規格歡迎另外訂購。

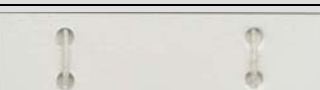
代號 WIRE CODE	規格 SPECIFICATION	說明 DESCRIPTION	環境溫度範圍 TEMP. RANGE	樣品 SAMPLE
WIC-H	4/0.65 * 2	玻璃纖維 CLASS FIBER	0 ~ 200°C	
WIC-H	7/0.65 * 2	玻璃纖維 CLASS FIBER	0 ~ 200°C	
				
WPR-H	4/0.65 * 2	玻璃纖維 CLASS FIBER	0 ~ 200°C	
WPR-H	7/0.65 * 2	玻璃纖維 CLASS FIBER	0 ~ 200°C	
				
TC-CA-G	4/0.32 * 2	素線級 PVC T/C GRADE	0 ~ 105°C	
W-CA-G	4/0.32 * 2	PVC	0 ~ 105°C	
W-CA-G	7/0.32 * 2	PVC	0 ~ 105°C	
W-CA-G	4/0.65 * 2	PVC	0 ~ 105°C	
W-CA-G-IS	4/0.65 * 2	PVC 鍍錫銅網內隔離 TINNED COPPER BRAIDED SHIELD	0 ~ 105°C	
W-CA-G	7/0.65 * 2	PVC	0 ~ 105°C	
				
W-IC-G	7/0.32 * 2	PVC	0 ~ 105°C	
W-IC-G	4/0.65 * 2	PVC	0 ~ 105°C	
				
W-CRC-G-IS	4/0.65 * 2	PVC 鍍錫銅網內隔離 TINNED COPPER BRAIDED SHIELD	0 ~ 105°C	

THERMOWELL 保護管訂購規格參考圖示。

訂購方法：請簡略描述(內徑)(外徑)(長度)(規格)請參考下圖。

實際圖像如右



參考圖示一

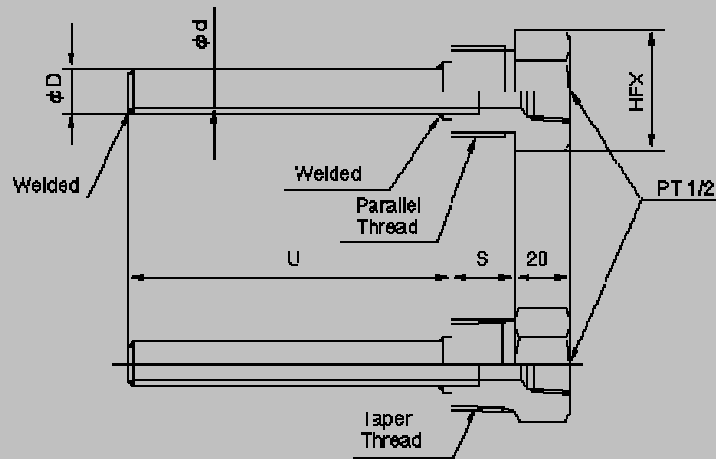

參考圖示二

